

SC UNO/DUO

Instructions for use



EN	Operating instructions	8
DE	Bedienungsanweisungen	13
FR	Instructions de fonctionnement	18
NL	Gebruiksaanwijzingen	23
IT	Istruzioni per l'uso	28
NO	Bruksanvisning	33
SV	Bruksanvisning	38
DA	Betjeningsvejledning	43
FI	Käyttöohje	48
ES	Instrucciones de funcionamiento	53
PT	Instruções de Funcionamento	58
EL	Οδηγίες λειτουργίας	63
TR	Kullanma Talimatları	69
SL	Navodila za delovanje	75
HR	Upute za uporabu	80
SK	Návod na obsluhu	85
CS	Návod k obsluze	90
PL	Instrukcje dotyczące obsługi	95
HU	Használati útmutató	101
RO	Instrucțiuni de utilizare	106
BG	Указания за експлоатация	111
RU	Руководство по эксплуатации	116
ET	Tööjuhised	122
LV	Norādījumi par ekspluatāciju	127
LT	Naudojimo instrukcija	132
JA	作手順.....	137
ZH	操作说明	142
KO	사용법.....	146
TH	คำแนะนำการใช้งาน	151
MS	Arahan Operasi.....	156

A

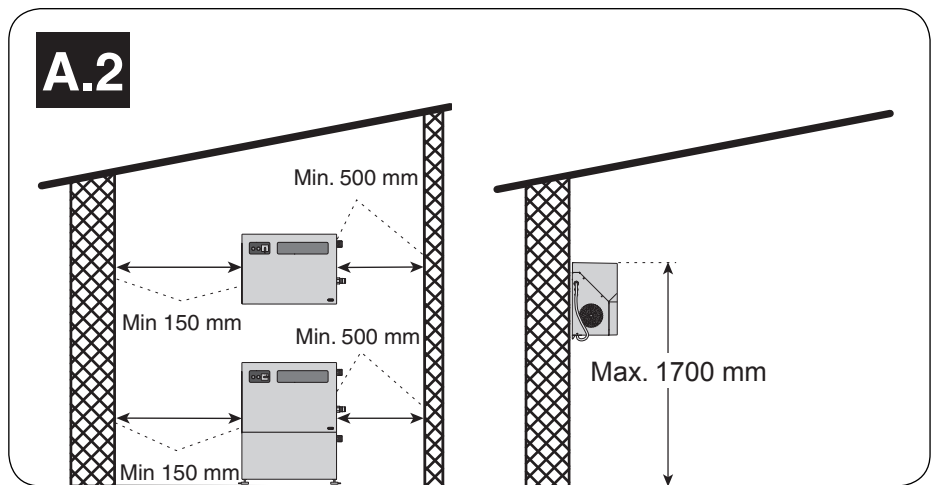
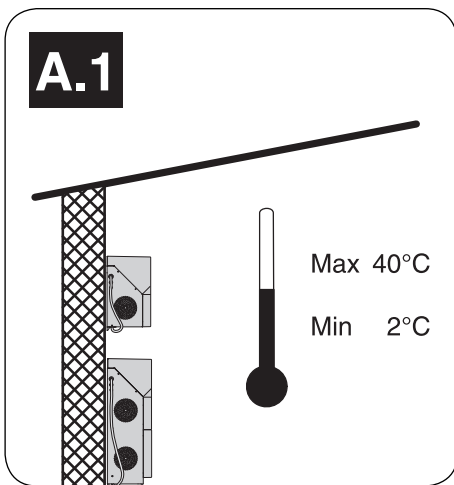
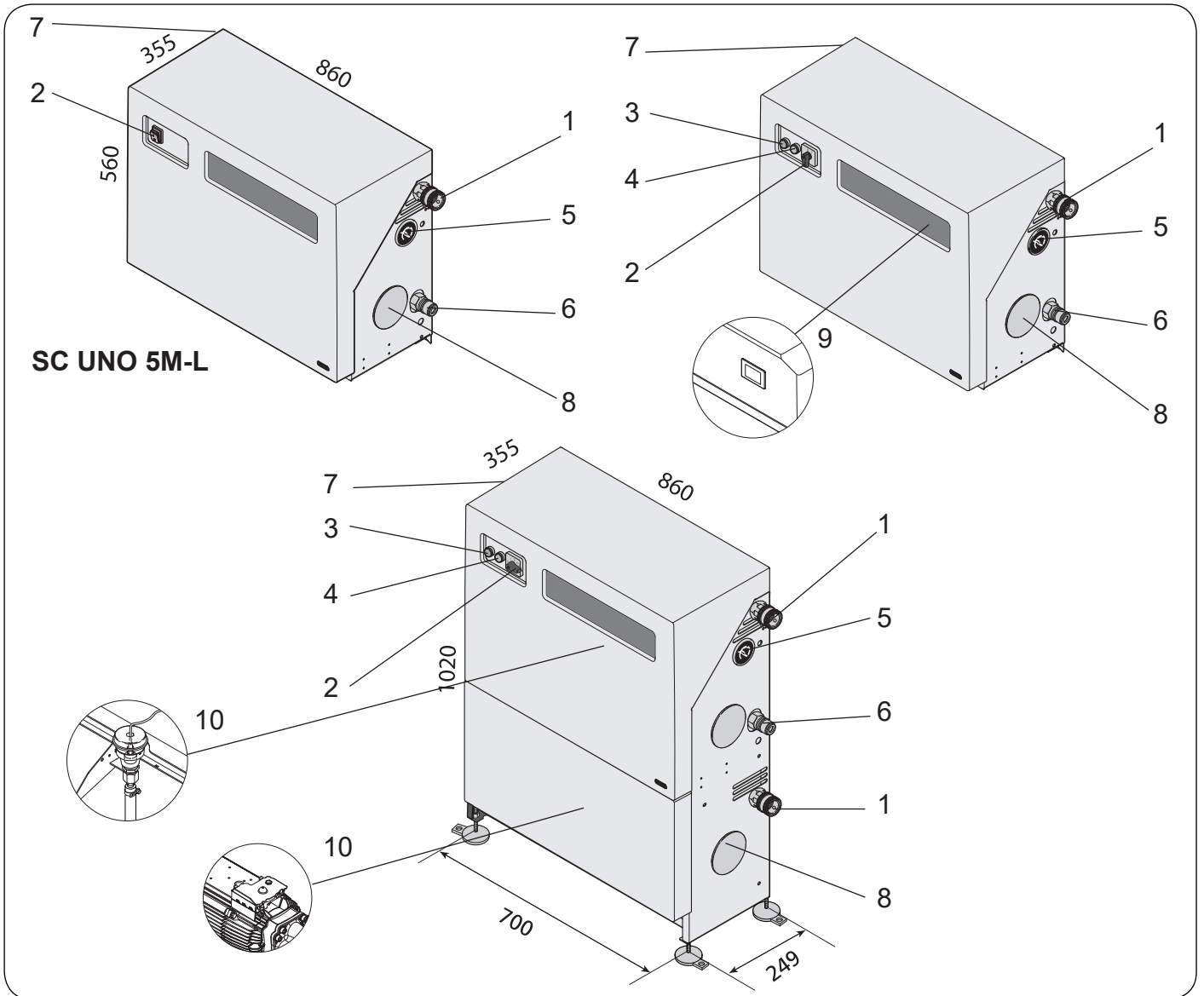

A

A.3

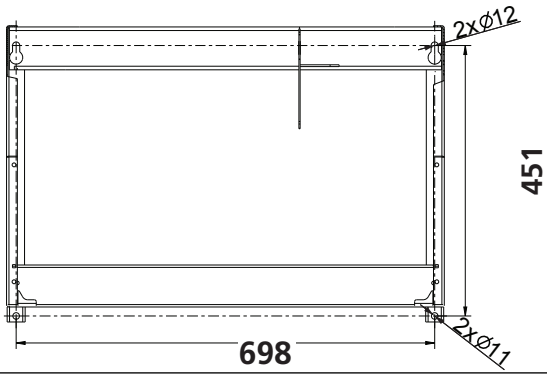

A.4

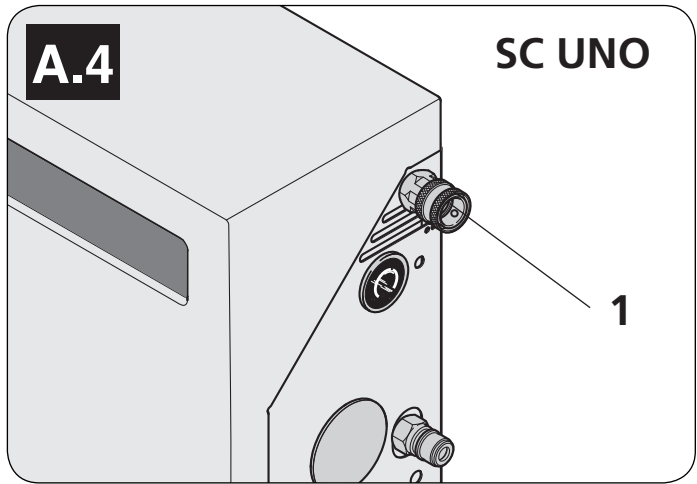

A.4

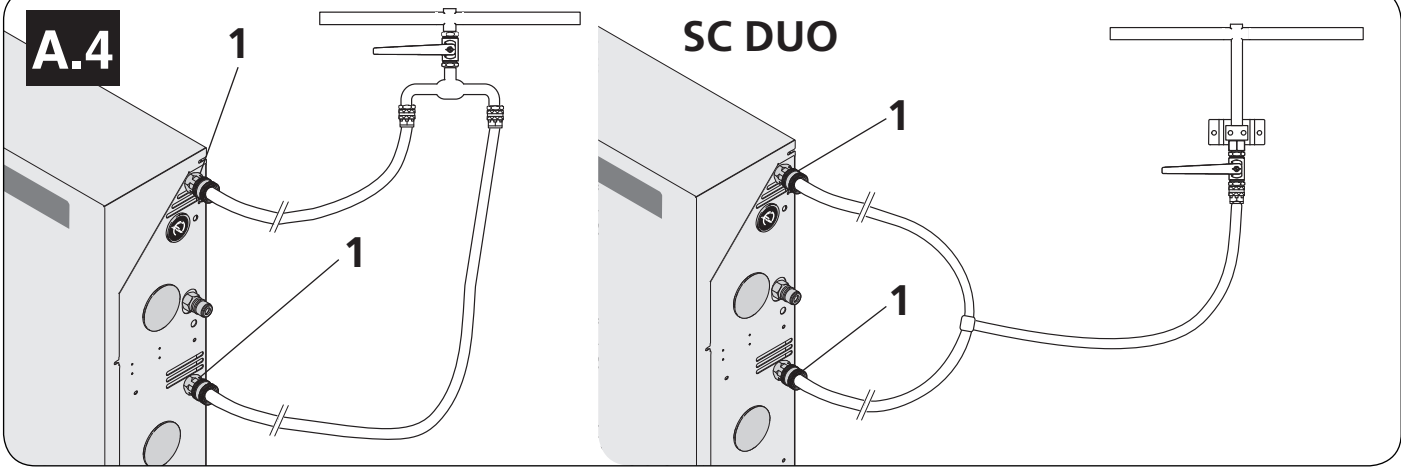

A.7

SC UNO

SC UNO 5M-L

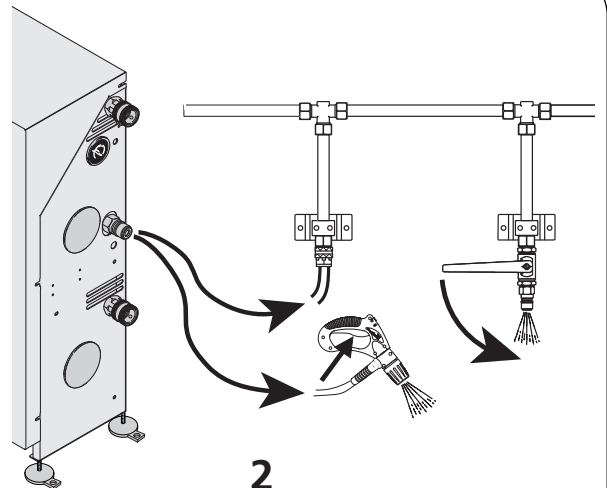
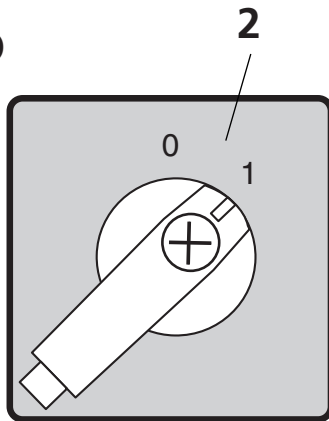
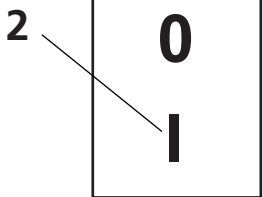

SC DUO

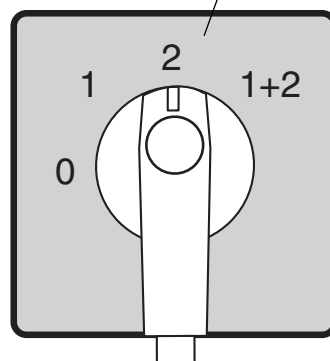
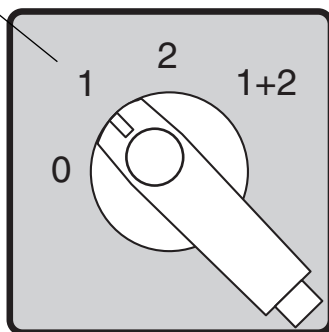
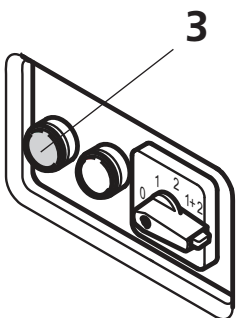

B

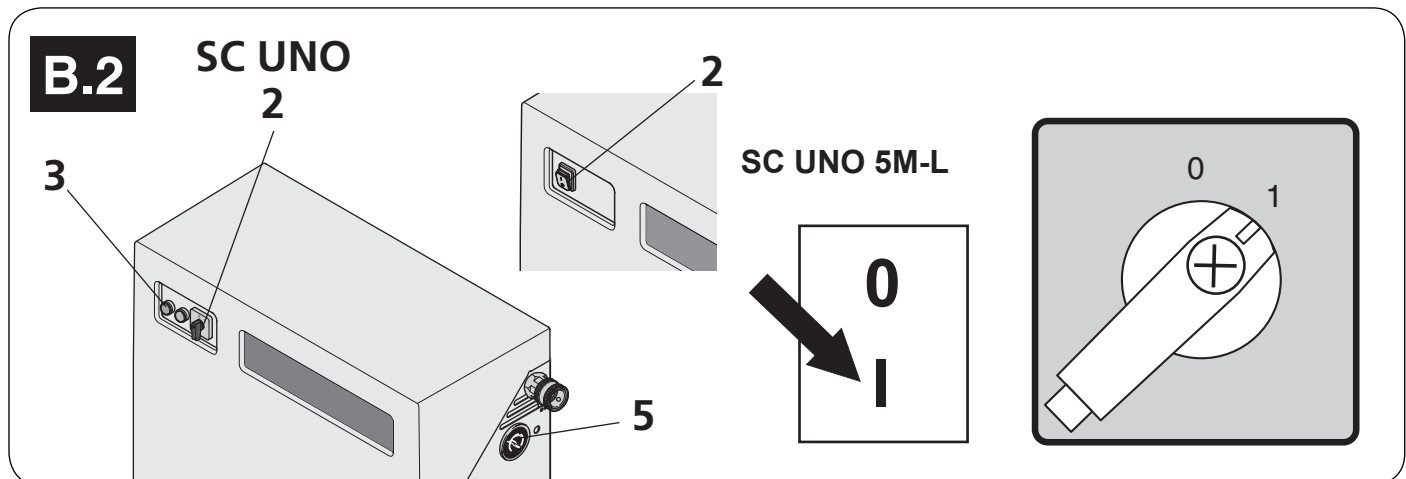
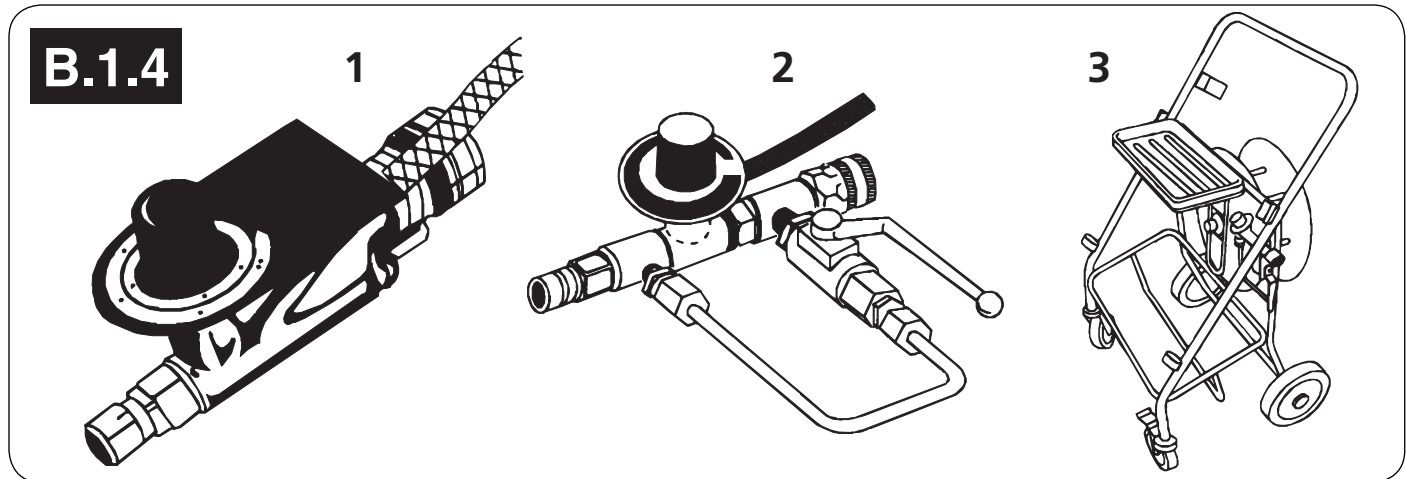
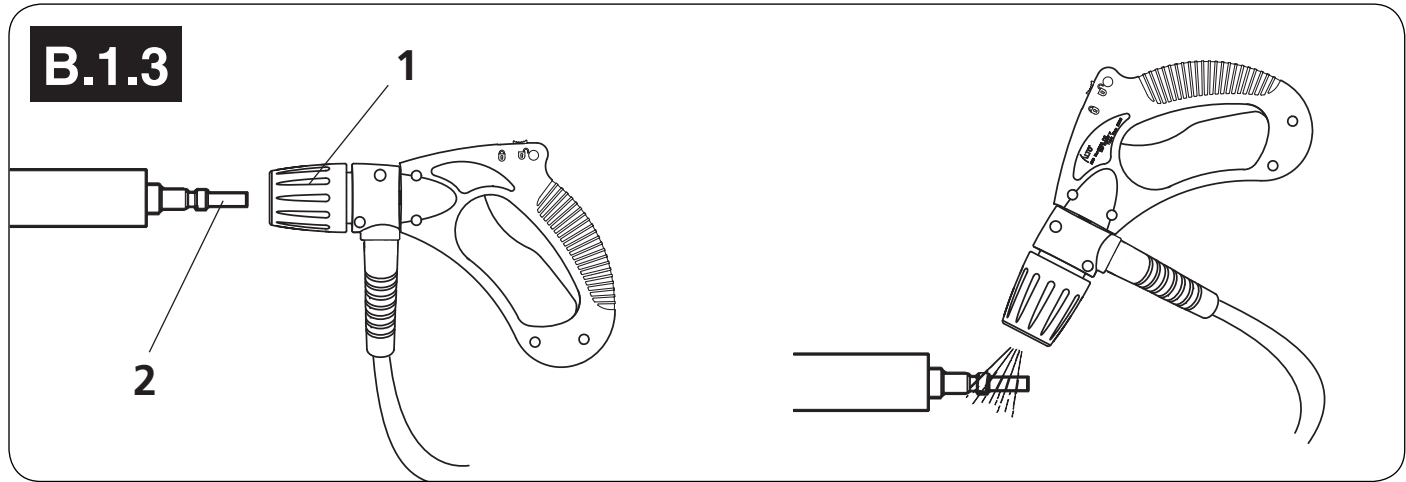
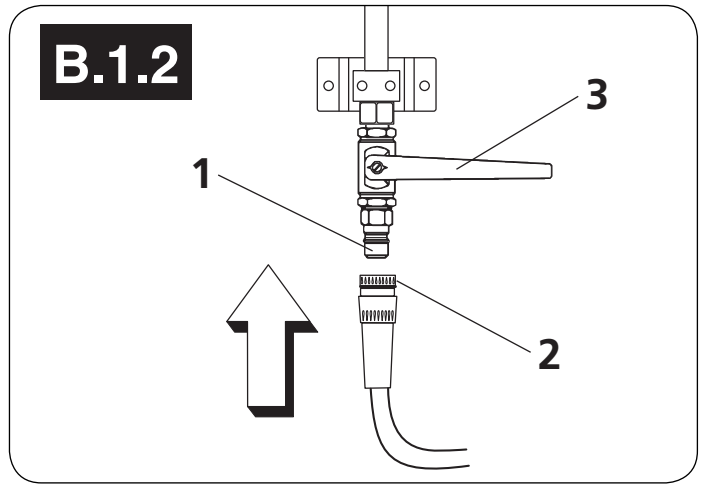
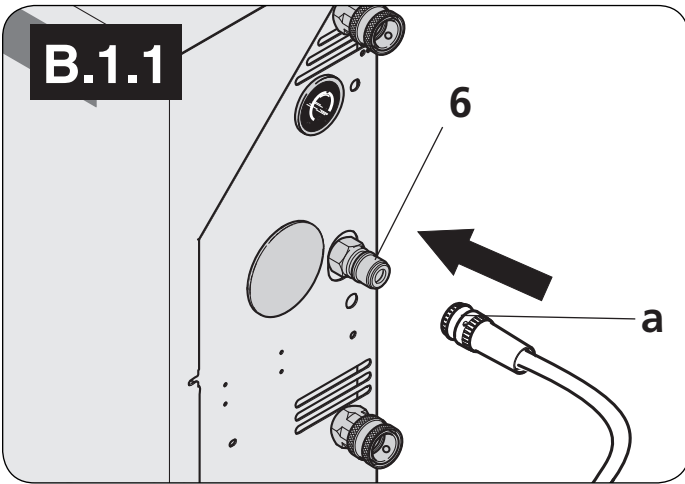

B

B.2 SC DUO

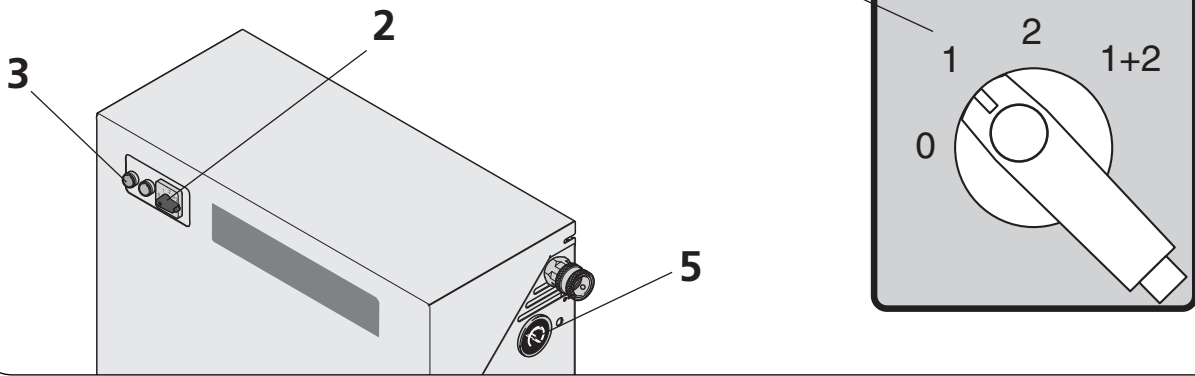

B.3

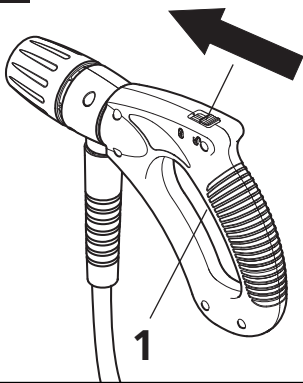

B.4

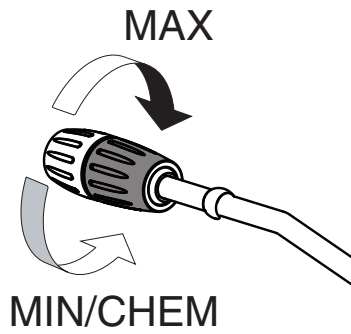

B.5

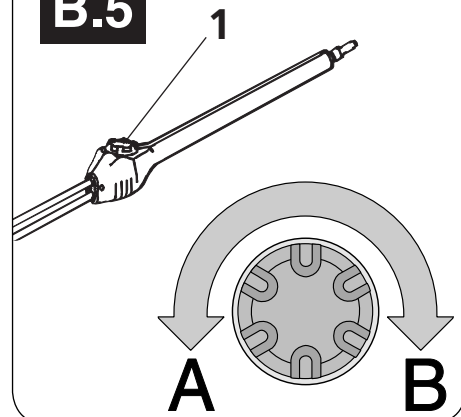

B.6

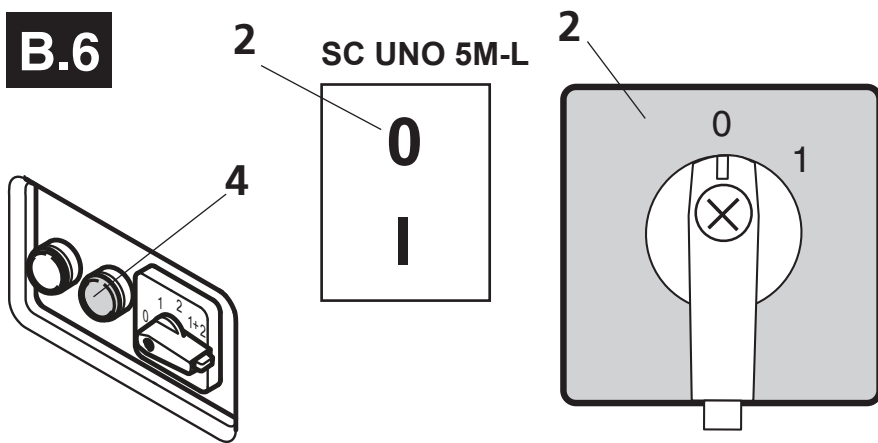

B.7

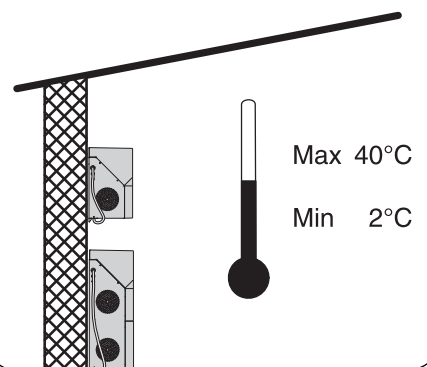

C

C.1

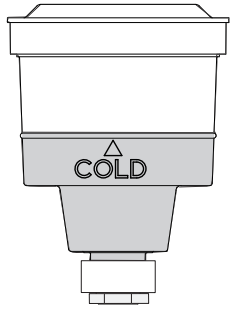

C.2

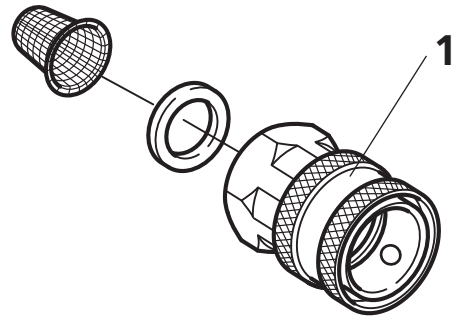

Operating Instructions

This high pressure washer has been developed for professional use within:

- agriculture, light industry, transport, building and construction, service

Only use the high pressure washer for purposes described in this manual.

Regarding the following sections:

- A - Installation**
- B - Operation**
- C - Maintenance**

please refer to pictures in front of the manual.

A - Installation

Before starting

DO READ SAFETY INSTRUCTIONS BEFORE USE!

Operating elements:

1. Water connection with filter
2. Main switch
3. Starting button
4. Stop button
5. Pressure gauge
6. Connection of high pressure hose
7. Electric cable
8. Service plug
9. Hour counter
10. Oil container

A.1 Temperature conditions

The machine should be installed in a frost-free room. This applies to pump as well as pipelines incl. of outlet points. Concerning outdoor outlet points it should be possible to close and empty that part of the line which is exposed to frost.

The maximum ambient temperature for the machine is 40°C.

A.2 Condition of distance

In consideration of the cooling system of the machine and the accessibility of service, there must be free wall space on both sides of the machine. To the right 500 mm at a minimum and to the left 150 mm at a minimum.

SC UNO:

The recommended installation height for the machine is max. 1700 mm measured from the upper edge of the machine.

A.3 Wall mounting

SC UNO:

Only mount the machine on a solid wall construction suited for the mounting of a machine. I.e. a concrete or brick wall.

Do not mount the machine on a wall where it will cause disturbances in neighbouring rooms (canteens, offices

etc.).

SC DUO:

Place the machine on a plane floor.

Machine feet have been mounted under the machine. These must be adjusted so that the machine stands stable. The feet may be bolted to the floor.

A.4 Water connection

The water connection is made through a flexible hose (minimum 2 m.) connected to the quick coupling on the water inlet(s) (1) of the machine.

The connection can be made to a water supply network or an internal water supply. A shut-off cock should be mounted on the water supply network in the immediate vicinity of the machine.

Max. water pressure: 10 bar

Min. water pressure: 1 bar

Max. water inlet temp.: See **Technical Specifications**.

If there is a risk of running sands or other impurities in the inlet water, a sand filter (50 micron) should be mounted beyond the internal filter of the machine (for further connection data see section **Technical Specifications**).

Clean the water inlet filter (1) once a month.

SC DUO:

Water inlet hoses must be connected to the same water tap.

A.5 Mains power connection

Connect the machine to an approved safety switch.

Check voltage, fuse, and cables according to **Safety Instructions**.

Connection data conc. power consumption can be taken from the model tag of the machine.

A.6 High pressure connection

IMPORTANT: When connecting to a pipeline always use a flexible hose connection from the outlet of the machine (pos. 6) - order no. 6300843. Contact your Nilfisk distributor for further information.

The outlet of the machine can be connected to a pipeline with fixed outlet points, or standard high pressure hoses can be connected directly to the outlet of the machine.

It is recommended to let a service technician authorized by Nilfisk prepare the pipeline.

A.7 Venting

SC UNO:

Turn main switch (2) to position - 1 -. Open the outlet point. Push the green starting button (3).

SC UNO 5M-L: Switch main switch to position - I -. Open the outlet point.

Let the water run until all air has escaped from the pump (even water flow).

In the case of a recently installed system, or if the pipeline and the pump have been emptied in any other way, the system should be vented by starting the pump and then

let the water run at each outlet point of the pipeline at turns.

When connecting the high pressure hose directly to the machine, the system should be vented by starting the pump and activating the trigger of the spray handle without having attached the spray lance.

SC DUO:

In the case of a recently installed system, or if the pipeline and the pump have been emptied in any other way, the system should be vented as follows:

1. At first start pump no. 1 and let the water run from an outlet point of the pipeline.
When connecting the high pressure hose directly to the machine, activate the trigger of the spray handle without having attached the spray lance.
Let the water run until all air has escaped from the pump (even water flow).
2. Stop pump no. 1. Then start pump no. 2 and let the water run from an outlet point of the pipeline.
When connecting the high pressure hose directly to the machine, activate the trigger of the spray handle without having attached the spray lance.
Let the water run until all air has escaped from the pump (even water flow).
3. Vent the pipeline by starting one pump and then let the water run at each outlet point of the pipeline at turns until all air has escaped from the system.

B - Operation

B.1 Connections

B.1.1 High pressure hose - directly on the machine

The Nilfisk high pressure hose with imprinted max. working pressure and temperature should be attached to the outlet connection of the machine (6) by the quick coupling (a).

Max. extension hose: 50 m.

Danger of scalding!

Never dismount high pressure hoses at water temperatures above 50°C.

IMPORTANT: Prior to dismounting of the high pressure hose the machine should be stopped and the shut-off cock closed. Then activate the trigger of the spray handle to relieve the high pressure hose of pressure.

B.1.2 High pressure hose - to outlet point

In the case of a pipeline with fixed outlet points the high pressure hose with imprinted working pressure and temperature should be attached to the nipple of the high pressure cock (1) by the quick coupling (2). Upon attachment turn the handle of the high pressure cock (3) to open position.

Danger of scalding!

Never dismount high pressure hoses at water temperatures above 50°C.

IMPORTANT: Prior to dismounting of the high pressure hose or when changing to another outlet point the high pressure cock should be carefully closed. Then activate the trigger of the spray handle to relieve the high pressure hose of pressure.

B.1.3 Spray handle - accessories

1. Pull forward the quick coupling trigger (1) of the spray handle.
2. Insert the nipple of the spray lance (2) in the quick coupling and release the trigger.
3. Pull forward the spray lance or any other accessory to ensure correct mounting before starting the machine.

NOTE!

Clean nipple of any impurities each time the spray lance has been dismounted.

B.1.4 Application of detergents (external)

If you want to apply detergents or disinfectants these should be dosed to the water through an injector. In conjunction with the injector it may be advantageous to use a wall rack on which spray lances, 2 pcs. of 25 l containers as well as 10 m high pressure hose can be placed.

Below you will find various types of outlet points with injectors.

1. Outlet point with detachable injector

To be attached to the quick coupling of the high pressure cock.

To be used for dosing of low-foaming detergents or disinfectants.

Dosage 1-8%.

2. Outlet point with detachable foam injector

To be attached to the quick coupling of the high pressure cock.

To be used in conjunction with foam lance for application of high-foaming detergents or disinfectants.

Dosage 1-5%.

3. Outlet point with cleaning trolley and foam injector

To be attached to the quick coupling of the high pressure cock.

To be used in the same way as "Outlet point with detachable foam injector".

Makes it possible to place 4 spray lances, 2 pcs. of 25 l containers as well as 20 m high pressure hose.

B.2 Start

The shut-off cock on the water inlet should be open.

SC UNO:

Turn the main switch (2) to position - 1 -. Press the green starting button (3).

SC UNO 5M-L: Switch main switch to position - I -).

Check on the pressure gauge (5) that a pressure is being

built up in the system. If a pressure is not being built up, vent the machine as described in section **A.7 Venting**.

SC DUO:

- Position **1** = Pump no. **1** in operation
- Position **2** = Pump no. **2** in operation
- Positions **1+2** = Pumps no. **1** and **2** in operation

Turn the main switch (2) to position **1**, **2** or **1+2**. Push the green starting button (3).

Check on the pressure gauge (5) that a pressure is being built up in the system. If a pressure is not being built up, vent the machine as described in section **A.7 Venting**.

B.3 Operation - automatic start/stop

Always hold the spray lance with both hands!

The machine is automatically activated when the trigger (1) of the spray handle is activated.

When the trigger is released, the machine automatically stops after 20 seconds.

When the machine is not in use, the trigger should be locked with locking device (see arrow).

The spray lance features 2 nozzles, a high pressure nozzle and a low pressure nozzle.

B.4 FlexoPowerPlus and PowerSpeedVario - pressure regulation

Turn the outermost part of the FlexoPowerPlus spray lance:

- High pressure = MAX
- Low pressure = MIN./CHEM.

B.5 Double spray lance, pressure regulation

The spray lance features 2 nozzles - a high pressure nozzle and a low pressure nozzle.

High pressure mode

When the pressure reducing valve (1) is completely closed (turned clockwise - **B**), only the high pressure nozzle is used - **high pressure mode**.

Low pressure mode

When the reducing valve (1) is completely opened (turned counterclockwise - **A**), both spray lances are used - **low pressure mode** / possibility of dosing detergents.

The pressure may be regulated between these positions.

B.6 Stop

Danger of scalding!

Never detach high pressure hoses at a water temperature above 50°C.

Never detach the high pressure hose while the machine is in operation.

1. To stop the machine, push the red stop button (4) and turn the main switch (2) to position - **0** -.

SC UNO 5M-L - switch main switch to position - **0** -.

2. Close the shut-off cock of the water inlet and activate the spray handle or open the high pressure cock to relieve the pipeline / high pressure hose of pressure.

B.7 Frost protection

The machine should be installed in a frost-free room. This applies to pump as well as pipelines incl. of outlet points. Concerning outdoor outlet points it should be possible to empty that part of the line which is exposed to frost.

IMPORTANT: For safety reasons, hoses, spray lances and other accessories should always be thawed prior to use.

C - Maintenance

It applies to the most exposed components that a minimum of maintenance ensures a prolonged and problem-free operation. Therefore it will be a good idea to make a habit of the following:

Prior to attaching the water hose and the high pressure hose, the quick couplings should be cleaned of dust and sand.

Prior to attaching the spray lance or other accessories to the spray handle, the machine should be started and the quick coupling cleaned of dust and sand.

C.1 Oil

Check the oil level in the oil glas.

If the oil level gets too low, the machine will automatically shut down. The red button will flash (does not apply to SC UNO 5M-L).

In the case of repeated low oil level (oil waste) please contact a Nilfisk service technician.

PROTECT THE ENVIRONMENT

Waste oil and oil sludge must be removed as laid down in the instructions.

C.2 Water filter

To avoid debris entering the high pressure pump, a water filter (fine) is fitted at the water inlet. Dependent on the purity of the water, this filter will have to be cleaned at regular intervals.

The filter can be removed when the quick coupling (pos. 1) has been unscrewed.

C.3 Cleaning of high pressure nozzle

A clogging up in the nozzle causes a pump pressure which is too high, and a cleaning is immediately required.

1. Stop the cleaner and detach the spray lance.
2. Clean the nozzle.
IMPORTANT: ONLY use the cleaning tool when the spray lance is detached.
3. Flush the spray lance backwards with water.
4. If the pressure is still too high, repeat items 1-3.

C.4 Disposable waste

This high pressure washer consists of parts which can affect the environment when thrown away. Parts that can pollute are as follows:

Oil, painted/zinc-coated parts, plastics/plastic-coated parts.

Therefore, it is important to follow the laws concerning the removal of polluting and dangerous materials when replacing spare parts or disposing of high pressure washer.

It is recommended that you bring the rejected parts to waste disposal areas or recycling plants that are approved for the destruction of these types of materials.

Troubleshooting

You have chosen the best quality and therefore deserve the best service. To avoid unnecessary disappointments, you should check the following before contacting the nearest Nilfisk service organisation:

Symptom	Reason	Action
Machine/pump will not start	<ul style="list-style-type: none"> > A fuse has blown > Power/plug not connected > Thermal switches in motor activated (red lamp flashes) > Thermal relay switched off (red lamp flashes) > Oil shortage in pump 	<ul style="list-style-type: none"> • Change the fuse. • Connect power/plug. • Let the motor cool. Start the machine and check that the working pressure is not too high and that the mains voltage corresponds to the specifications. • Refill with oil.
Fuses blow	<ul style="list-style-type: none"> > Installation does not correspond to the ampere consumption of the machine 	<ul style="list-style-type: none"> • Change to an installation corresponding to the ampere consumption of the machine at a minimum. Replace the fuse.
Working pressure too low	<ul style="list-style-type: none"> > Nozzle worn > Wrong spray lance > Reduction valve of spray lance not adjusted to max. pressure. > Nozzle partly clogged up 	<ul style="list-style-type: none"> • Replace the nozzle. • Replace the spray lance (see section B4/B5). • Turn reduction valve completely counter-clockwise. • Clean the nozzle (see section C.3).
Working pressure not steady	<ul style="list-style-type: none"> > Water temperature too high > Insufficient water supply > High pressure hoses too long > Air in the system > Water inlet filter clogged up 	<ul style="list-style-type: none"> • Lower the temperature of the inlet water to max. temperature (see Technical Specifications). • Check water inlet filter. If that does not solve the problem, the water supply for the machine is insufficient. NB! Avoid long, thin hoses (min. 3/4"). • Dismount high pressure extension hoses and retry. Extension hose max. 50 m. NB! Avoid long extension hoses with many couplings. • Vent the system (see section A.7). • Clean filter (see sect. D.2)
No working pressure	<ul style="list-style-type: none"> > Nozzle clogged up > No inlet water > High pressure cock of outlet point open. 	<ul style="list-style-type: none"> • Clean nozzle (see sect. D.3) • Check that the shut off cock of the water inlet is open. Check that the water supply meets the requirements (see section A.4) • Close all high pressure cocks not in use.
Machine starts and stops	<ul style="list-style-type: none"> > Leaky hose/ pipeline/spray handle 	<ul style="list-style-type: none"> • Repair leak.
Machine stops	<ul style="list-style-type: none"> > Oil shortage in pump. Red lamp flashes 	<ul style="list-style-type: none"> • Top up with oil.
Machine hour counter is not showing the hours. Machine function wrong - not correct starts and stops, red LED flashes without any failures	<ul style="list-style-type: none"> > Mains power unstable > Control system error 	<ul style="list-style-type: none"> • Turn mains power off for min. 1 minute. • Press red button for 5 sec. to reset microprocessor.

Should other malfunctions occur than those mentioned above, please contact your nearest Nilfisk service organisation.

Warranty

Your Nilfisk product is guaranteed for 12 months from date of purchase (purchase receipt must be presented) on the following conditions:

- that defects are attributable to flaws or defects in materials or workmanship. (Usual wear and tear as well as misuse are not covered by the guarantee).
- that repairs have not been carried out or attempted by other than Nilfisk-trained service staff.
- that only original accessories have been applied.
- that the product has not been exposed to abuse such as knocks, bumps or frost.
- that the instructions in the manual have been carefully observed.

















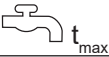

A warranty repair comprises the replacement of defective parts, but it does not cover freight and packaging charges. Besides we refer to national Sale of Goods Act.

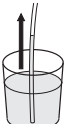
Any **illegitimate** guarantee repair will be invoiced. (I.e. malfunctions due to **causes** mentioned in section “**Troubleshooting**” of the instruction manual).













Maintenance plan

	Weekly	Every 500 operating hours	As required
Water filters			●
Grease quick coupling nipples for hose, gun and lance	●		
Check the pump oil quality	●		
Change the pump oil		©Nilfisk Service	

















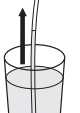

Specifications

			SC UNO 5M- 200/1050 L	SC UNO 5M- 200/1050	SC UNO 6P- 170/1610	SC UNO 7P- 180/1200	SC UNO 7P- 180/1200 EXPT
1			EU 欧盟	EU 欧盟	EU 欧盟	EU 欧盟	EXP
2		V/ph/Hz	400/3/50	400/3/50	400/3/50	400/3/50	440/3/60
3		A	16	16	16	16	16
4		kW кВт	6.1	6.1	8.8	6.7	6.7
5	 P _{IEC}	bar (MPa) Бар (МПа) 巴 (兆帕)	200 (20)	200 (20)	170 (17)	180 (18)	180 (18)
6	 Q _{IEC}	l/h л/час 升/小时	960	960	1500	1080	1080
7	 P _{max}	bar (MPa) Бар (МПа) 巴 (兆帕)	250 (25)	250 (25)	250 (25)	250 (25)	250 (25)
8	 Q _{max}	l/h	1050	1050	1600	1200	1200
9	 t _{max}	°C (°F)	60 (140)	60 (140)	80 (176)	80 (176)	80 (176)
10	 p _{max}	bar (MPa) Бар (МПа) 巴 (兆帕)	10 (1)				
11	 p _{min}	bar (MPa) Бар (МПа) 巴 (兆帕)	1 (0.1)				
12		m 米	1				
13		mm 毫米	355x860x560				
14	 kg	kg кг	74	74	84	81	81
15	 L _{PA} (IEC 60335-2-69)	dB(A)+/-2 дБ(А)+/-2	68	68	77	78	78
16	 L _{WA} (IEC 60335-2-69)	dB(A)+/-2 дБ(А)+/-2	86	86	91	84	84
17	 a _h (ISO 5349 a _h)	m/s ² 米/秒 ²	<1.5 +/- 1	<1.5 +/- 1	<1.5 +/- 1	<1.5 +/- 1	<1.5 +/- 1
18		N	46.3	46.3	67.8	54.8	54.8
19		L 升	0.73	0.73	0.95	1	1
20	 TYPE		Castrol ALPHASyn 150				





















Specifications







		SC DUO 6P- 170/3220	SC DUO 7P- 180/2400	SC DUO 7P- 180/2400 EXPT	SC UNO 8P 180/2000	
1		EU 欧盟	EU 欧盟	EXP	EU 欧盟	
2		V/ph/Hz	400/3/50	400/3/50	440/3/60	400/3/50
3		A	32	32	32	25
4		kW кВт	18	16.4	16.4	11
5	 P _{IEC}	bar (MPa) Бар (МПа) 巴 (兆帕)	170 (17)	180 (18)	180 (18)	180 (18)
6	 Q _{IEC}	l/h л/час 升/小时	3000	2240	2240	1800
7	 P _{max}	bar (MPa) Бар (МПа) 巴 (兆帕)	250 (25)	250 (25)	250 (25)	250 (25)
8	 Q _{MAX}	l/h	3220	2400	2400	2000
9	 t _{max}	°C (°F)	80 (176)	85 (185)		80 (176)
10	 p _{max}	bar (MPa) Бар (МПа) 巴 (兆帕)	10 (1)			
11	 p _{min}	bar (MPa) Бар (МПа) 巴 (兆帕)	1 (0.1)			
12		m 米	1	1	1	
13		mm 毫米	355x860x1000			355x860x60
14		kg кг	180	160	160	100
15	 L _{PA} (IEC 60335-2-69)	dB(A)+/-2 дБ(A)+/-2	79	79	79	77
16	 L _{WA} (IEC 60335-2-69)	dB(A)+/-2 дБ(A)+/-2	93	93	93	91
17	 a _h (ISO 5349 a _h)	m/s ² 米/秒 ²	<1.5 +/- 1			
18		N	135	115.7	107.5	-
19		L 升	1			0.95
20	 TYPE		Castrol ALPHASyn 150			





Specifications





		SC UNO 8P 160/2500	SC UNO 8P- 180/2000 EXPT	SC DUO 8P- 180/4000	SC DUO 8P- 160/5000
1		EU 欧盟	EXP	EU 欧盟	EU 欧盟
2		V/ph/Hz	400/3/50	440/3/60	400/3/50
3		A	25	25	50
4		kW кВт	11	12	22
5	 P _{IEC}	bar (MPa) Бар (МПа) 巴 (兆帕)	160 (16)	180 (18)	180 (18)
6	 Q _{IEC}	l/h л/час 升/小时	2400	1800	3600
7	 P _{max}	bar (MPa) Бар (МПа) 巴 (兆帕)	250 (25)	250 (25)	250 (25)
8	 Q _{MAX}	l/h	2500	2000	4000
9	 t _{max}	°C (°F)	80 (176)		
10	 p _{max}	bar (MPa) Бар (МПа) 巴 (兆帕)	10 (1)		
11	 p _{min}	bar (MPa) Бар (МПа) 巴 (兆帕)	1 (0.1)		
12		m 米	1		
13		mm 毫米	355x860x60		355x860x1000
14	 kg	kg кг	100	100	212
15	 L _{PA} (IEC 60335-2-69)	dB(A)+/-2 дБ(A)+/-2	77	77	80
16	 L _{WA} (IEC 60335-2-69)	dB(A)+/-2 дБ(A)+/-2	91	91	94
17	 a _h (ISO 5349 a _h)	m/s ² 米/秒 ²	<1.5 +/- 1		
18		N	-	-	-
19		L 升	0.95		1
20	 TYPE		Castrol ALPHASyn 150		



Specifications

			SC DUO 8P 180/4000 EXPT
1			EXP
2		V/ph/Hz	440/3/60
3		A	50
4		kW кВт	22
5	 P _{IEC}	bar (MPa) Бар (МПа) 巴 (兆帕)	180 (18)
6	 Q _{IEC}	l/h л/час 升/小时	3600
7	 P _{max}	bar (MPa) Бар (МПа) 巴 (兆帕)	250 (25)
8	 Q _{MAX}	l/h	4000
9	 t _{max}	°C (°F)	80 (176)
10	 p _{max}	bar (MPa) Бар (МПа) 巴 (兆帕)	10 (1)
11	 p _{min}	bar (MPa) Бар (МПа) 巴 (兆帕)	1 (0.1)
12		m 米	1
13		mm 毫米	355x860x1000
14		kg кг	212
15	 L _{PA} (IEC 60335-2-69)	dB(A)+/-2 дБ(A)+/-2	80
16	 L _{WA} (IEC 60335-2-69)	dB(A)+/-2 дБ(A)+/-2	94
17	 a _h (ISO 5349 a _h)	m/s ² 米/秒 ²	<1.5 +/- 1
18		N	-
19		L 升	1
20	 TYPE		Castrol ALPHASyn 150

1			EN: Country variant. DE: Ländervarianten. FR: Selon le pays. NL: Nationale variant. IT: Variante per il Paese. NO: Variant i ulike land. SV: Landsvariant. DA: Landespecifik variant. FI: Maakohtainen vaihtelu. ES: Dependencia del país. PT: Variante do país. EL: Έκδοση χώρας. TR: Ülkedeki model. SL: Jezikovna različica. HR: Ovisno o zemlji. SK: Vrsta ulja. CS: Varianta země. PL: Wersja dla kraju. HU: Országfüggő modellváltozatok. RO: Varianta țării. BG: Вариант за страната. RU: Региональное исполнение. ET: Riigi variant. LV: Valsts versija. LT: Šalių skirtas variantas. JA: 国による相違。 ZH: 不同国家 KO: 국가별 모델. TH: แตกต่างกันไป ตามประเทศ MS: Variasi negara.
2		V/ph/Hz	EN: Possible voltage. DE: Mögliche Spannung. FR: Tension autorisée. NL: Mogelijke spanning. IT: Possibile voltaggio. NO: Mulig spenning. SV: Möjlig spänning. DA: Spænding. FI: Mahdollinen jännite, V/vaiheluku/taajuus. ES: Tensión admittida. PT: Tensão possível. EL: Πιθανή τάση, V/ph/Frez. TR: Olası voltaj, V/Faz/Frekans. SL: Morebitna napetost. HR: Mogući napon. SK: Možné napätie. CS: Možné napětí. PL: Dopuszczalne napięcie, V/fazy/częst. HU: Táp feszültség, V/fázis/frekv. RO: Tensiune posibilă, V/fază/Frecv. BG: Възможно напрежение. LV: Напряжение, В/φ./част. В/φ./Гц. ET: Võimalik pinge, V/faas/sagedus. RU: Iespëjamais spriegums. LT: Galima įtampa V / F / Frez. JA: 電圧。 ZH: 可能电压 (V/ph/ Frez) KO: 허용 전압, 볼트/상/헤르츠. TH: แรงดันไฟฟ้าที่สามารถใช้ได้ MS: Kemungkinan voltan.
3		A	EN: Fuse. DE: Sicherung. FR: Fusible. NL: Zekering. IT: Fusibile. NO: Sikring. SV: Säkring. DA: Sikring. FI: Sulake. ES: Fusible. PT: Fusível. EL: Ασφάλεια. TR: Sigorta. SL: Varovalka HR: Osigurač SK: Poistka CS: Pojistka. PL: Bezpiecznik. HU: Biztosíték. RO: Siguranță. BG: Предпазител RU: Предохранитель. ET: Kaitse. LV: Drošinātājs. LT: Saugiklis. JA: ヒューズ ZH: 保险丝 KO: 퓨즈. TH: ฟิวส์ MS: Fius
4		kW кВт	EN: Power rating. DE: Nennleistung. FR: Puissance nominale. NL: Nominaal vermogen. IT: Corrente nominale. NO: Nominell effekt. SV: Märkeffekt. DA: Nominel effekt. FI: Tehontarve. ES: Potencia nominal. PT: Classificação de potência. EL: Ονομαστική ισχύς. TR: Elektrik değeri. SL: Moč. HR: Oznaka napona. SK: Stanovenie výkonu. CS: Jmenovitý výkon. PL: Moc znamionowa. HU: Névleges teljesítmény. RO: Putere nominală. BG: Мощност. RU: Номинальная мощность кВт. ET: Vooluühik. LV: Nominālā jauda. LT: Galia. JA: 定格電力。 ZH: 额定功率 KO: 전원 등급. TH: อัตรากำลังไฟ MS: Penarafan kuasa.
5		bar (MPa) Бар (МПа) 巴 (兆帕)	EN: Working pressure. DE: Arbeitsdruck. FR: Pression de service. NL: Werkdruk. IT: Pressione di esercizio. NO: Arbeidstrykk. SV: Arbetstryck. DA: Arbejdstryk. FI: Työpaine. ES: Presión de trabajo. PT: Pressão de trabalho. EL: Πίεση λειτουργίας. TR: Çalışma basıncı. SL: Delovni tlak. HR: Radni tlak. SK: Pracovní tlak. CS: Provozní tlak. PL: Ciśnienie robocze. HU: Üzemi nyomás. RO: Presiune de lucru. BG: Работно налягане. RU: Рабочее давление. ET: Töösurve. LV: Darba spiediens. LT: Darbinis slėgis. JA: 動作圧力。 ZH: 工作压力 KO: 작업 압력. TH: แรงดันขณะใช้งาน MS: Tekanan kerja
6		l/h л/час 升/小时	EN: Water flow. DE: Wasserdurchsatz. FR: Débit d'eau. NL: Waterdoorstroming. IT: Flusso dell'acqua. NO: Vanntilførsel. SV: Vattenflöde. DA: Vandmængde. FI: Vedenvirtaus. ES: Flujo de agua. PT: Fluxo de água. EL: Ποή νερού. TR: Su akışı. SL: Pretok vode. HR: Regulacija protoka vode. SK: Prietok vody. CS: Průtok vody. PL: Przepływ wody. HU: Vízátfolyás. RO: Debit apă. BG: Воден поток. RU: Расход воды. ET: Veevool. LV: Ūdens plūšma. LT: Vandens srautas. JA: 流水 ZH: 水流量 KO: 급수량. TH: การไหลของน้ำ MS: Aliran air.
7		bar (MPa) Бар (МПа) 巴 (兆帕)	EN: Max. water pressure. DE: Max Wasserdruck. FR: Pression d'eau maximale. NL: Max. waterdruk. IT: Max. pressione dell'acqua. NO: Maks. vanntrykk. SV: Max vattentryck. DA: Max. vandtryk. FI: Suurin vedenpaine. ES: Presión máxima de entrada del agua. PT: Pressão máxima de água. EL: Μέγ. πίεση νερού. TR: Maks. su basıncı. SL: Najv. vodni tlak. HR: Maksimalni tlak vode. SK: Maximálny tlak vody. CS: Max. tlak vody. PL: Maks. ciśnienie wody. HU: Max. víznyomás. RO: Presiune max. apă. BG: Макс. налягане на водата. RU: Макс. давление воды. ET: Max veesurve. LV: Maks. ūdens spiediens. LT: Maks. vandens slėgis. JA: 最高水圧 ZH: 最大水圧 KO: 최대 수압. TH: ความดันน้ำสูงสุด MS: Tekanan air maksimum.

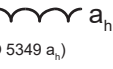
8	 Q_{max}	l/h	EN: Water flow DE: Wasserdurchsatz. FR: Débit d'eau. NL: Waterdoorstroming. IT: Flusso dell'acqua. NO: Vanntilførsel. SV: Vattenflöde. DA: Vandmængde. FI: Vedevirtaus. ES: Flujo de agua. PT: Fluxo de água. EL: Ποή νερού. TR: Su akışı. SL: Pretok vode. HR: Protok vode. SK: Prietok vody. CS: Průtok vody. PL: Przepływ wody. HU: Vízfolyás. RO: Debit apă. BG: Воден поток. RU: Расход воды. ET: Veevool. LV: Ūdens plūšma. LT: Vandens srautas. JA: 流水。 ZH: 水流。 KO: 급수량. TH: การไหลของน้ำ MS: Aliran air.
9	 t_{max}	°C (°F)	EN: Max water inlet temperature, Intake-Pressure operation. DE: Max Wassereinlassstemperatur - Druckbetrieb. FR: Température max. de l'entrée d'eau en mode admission/pression. NL: Max. Waterinlaattemperatuur Inlaat-Tijdens. Bedrijf. IT: Temperatura max. alimentazione acqua Funzionamento a ingressopressione. NO: Maks. temperatur vanninntak, Inntakstrykk drift. SV: Max ingående vattentemperatur inlopps-tryckdrift. DA: Maks. vandtilgangstemperatur, tilgangstrykdrift. FI: Tuloveden suurin lämpötila, käytettäessä painepesurina. ES: Temperatura y presión máxima de entrada del agua. PT: Temperatura máxima de entrada de água, Funcionamento da pressão de entrada. EL: Μεγ. θερμοκρασία εισόδου νερού-λειτουργίας πίεσης. TR: Maks. su girişi sıcaklığı Emme-Basınçlı çalışma. SL: Najv. vstopna temperatura vode, vstopni tlak pri delovanju. HR: Maks. temperatura ulazne vode, tlak pri usisavanju. SK: Max. vstupná teplota vody, Prevádzka v nasávacom režime pod tlakom. CS: Max. teplota vody na vstupu, provozní sací tlak. PL: Maks. temperatura na dopływie wody z instalacji wodociągowej. HU: Max. bemenő vízhőmérséklet Szívónyomásos üzem. RO: Temperatura max. de admisie apă în cazul alimentării de la robinet. BG: Макс. температура на входящата вода – работа в режим на засмукване. RU: Макс. температура воды на входе (всасывание/подача под давлением). ET: Max vee sisselasketemperatuur Sissevõtutõhk töö ajal. LV: Maks. ūdens ieplūdes temperatūra ieplūdes-spiediena darbībā. LT: Didžiausia vandens paėmimo temperatūra, veikimas esant įėjimo slėgiui. JA: 最高流入水温度、吸気圧力動作。 ZH: 进水压力操作时的最高进水水温 KO: 최대 급수 온도 주입/압력 작동. TH: อุณหภูมิน้ำเข้าสูงสุด ความดันในการใช้งานบริเวณทางเข้า MS: Suhu maksimum air masuk, Kemasukan-Operasi tekanan.
10	 p_{max}	bar (MPa) Бар (МПа) 巴 (兆帕)	EN: Max. water inlet pressure. DE: Max. Wassereinlassdruck. FR: d'eau en mode admission/pression. NL: Max. waterinlaatdruk. IT: Pressione max. alimentazione acqua. NO: Maks. trykk vanninntak. SV: Max tryck för vatteninlopp. DA: Maks. Vandtilgangstryk. FI: Tuloveden suurin paine. ES: Presión máxima de entrada del agua. PT: Pressão máxima de entrada de água. EL: Μεγ. πίεση εισόδου νερού. TR: Maks. su girişi basıncı. SL: Najv. tlak dovoda vode. HR: Maks. tlak ulazne vode. SK: Max. vstupný tlak vody. CS: Max. tlak vody na vstupu. PL: Maks. ciśnienie na dopływie wody. HU: Max. bemenő nyomás. RO: Presiunea max. de alimentare cu apă. BG: Макс. налягане на входяща вода. RU: Макс. давление воды на входе. ET: Maks vee sissevoolusurve. LV: Maks. ūdens spiediēns. LT: Didžiausias vandens paėmimo slėgis. JA: 最高流入水圧。 ZH: 最大进水压力 KO: 최고 급수 압력. TH: ความดันน้ำเข้าสูงสุด MS: Tekanan maksimum air masuk.
11	 p_{min}	bar (MPa) Бар (МПа) 巴 (兆帕)	EN: Min. water inlet pressure. DE: Min. Wassereinlassdruck. FR: d'eau en mode admission/pression Min. NL: Min. waterinlaatdruk. IT: Pressione min. alimentazione acqua. NO: Min. trykk vanninntak. SV: Min tryck för vatteninlopp. DA: Min. vandtilgangstryk. FI: Tuloveden suurin paine. ES: Presión mínima de entrada del agua. PT: Pressão min. de entrada de água. EL: Ελάχιστη πίεση εισόδου νερού. TR: Min. su girişi basıncı. SL: Minimalni tlak dovoda vode. HR: Min. tlak ulazne vode. SK: Min. vstupný tlak vody. CS: Min. tlak vody na vstupu. PL: Min. ciśnienie na dopływie wody. HU: Min. bemenő nyomás. RO: Presiunea min. de alimentare cu apă. BG: Макс. налягане на входяща вода. RU: Минимально давление воды на входе. ET: Min vee sissevoolusurve. LV: Min ūdens spiediēns. LT: Minimalus vandens paėmimo slėgis JA: 最低流入水圧。 ZH: 最低进水压力。 KO: 최저 유입수압. TH: แรงดันน้ำเข้าของน้ำต่ำสุด MS: Tekanan minimum air masuk.

12		m 米	<p>EN: Max dry suction height. DE: Max. Trockensaughöhe. FR: Hauteur d'aspiration à sec max. NL: Max. droge aanzuighoogte. IT: Altezza massima di aspirazione secco. NO: Maks. sugehøyde tørr. SV: Max torrsugningshöjd. DA: Maks. sugehøjde, tør. FI: Suurin kuivaimukorkeus. ES: Altura máxima de succión en seco. PT: Altura de aspiração a seco máx. EL: Μέγ. ύψος αναρρόφησης. TR: Maks. Kuru emme yüksekliği. SL: Najv. višina suhega vsesavanja. HR: Maks. visina pri suhom usisavanju. SK: Max. suchá nasávacia výška. CS: Max. sací výška nasucho. PL: Maks. wysokość ssania na sucho. HU: Max. száraz szívómagasság. RO: Înălțime max. de aspirare în cazul alimentării cu apă dintr-un recipient. BG: Макс. височина на сухо засмукване. RU: Макс. высота всасывания. ET: Max kuivimu kõrgus. LV: Maks. sausās sūkšanas augstums. LT: Maksimalus sausas įsiurbimo aukštis. JA: 最大乾燥吸込高さ。 ZH: 最大干吸高度 米 KO: 최대 건조 흡입 높이. TH: ความสูงของท่อดูดแห้งสูงสุด MS: Ketinggian maksimum sedutan kering.</p>
13		mm 毫米	<p>EN: Dimensions LxWxH. DE: Masse LxBxH. FR: Dimensions l x p x h. NL: Afmetingen LxBxH. IT: Dimensioni, lun. x larg. x alt. NO: Mål LxBxH. SV: Dimensioner LxBxH. DA: Mål LxBxH. FI: Mitat, PxLxK. ES: Dimensiones l x a x al. PT: Dimensões, C x L x A. EL: Διαστάσεις, Μ x Π x Υ. TR: Boyutlar, u x g x y. SL: Mere D x Š x V. HR: Dimenzije DxŠxV. SK: Rozmery D x Š x V. CS: Rozměry d x š x v. PL: Wymiary długość x szer. x wys. HU: Méretek H x Sz x M. RO: Dimensiuni. L x l x î. BG: Размери Д x Ш x В. RU: Размеры, Дл. x Шир. x Выс. ET: Mõõtmed p x l x k. LV: Izmēri G x P x A. LT: Matmenys (i x p x a). JA: 外形寸法長さx幅x高さ。 ZH: 尺寸 (长 x 宽 x 高) 毫米 KO: 크기(l x w x h). TH: ขนาด ยาว x กว้าง x สูง MS: Dimensi LxWxH.</p>
14		kg кг	<p>EN: Weight. DE: Gewicht. FR: Poids du nettoyeur. NL: Gewicht van de hogedrukreiniger. IT: Peso dell'idropulitrice. NO: Vekt høytrykksvasker. SV: Maskinens vikt. DA: Vægt. FI: Pelkän painepesurin paino. ES: Peso del limpiador. PT: Peso da máquina de limpeza. EL: Βάρος μηχανήματος καθαρισμού. TR: Temizlik makinesinin yüksekliği. SL: Masa. HR: Težina. SK: Hmotnosť. CS: Hmotnost čisticího stroje. PL: Ciężar myjki. HU: Tisztítógép tömege. RO: Greutatea aparatului. BG: Тегло. RU: Вес моечной машины. ET: Pesuri kaal. LV: Tīrītāja svārs. LT: Valymo įrenginio svoris. JA: 重量。 ZH: 清洗机重量 KO: 세척기 무게. TH: น้ำหนัก MS: Berat.</p>
15		dB(A) +/-2 дБ(A) +/-2	<p>EN: Sound pressure level L_{PA}. DE: Schalldruckpegel FR: Niveau de pression acoustique NL: Geluidsdrumniveau IT: Livello pressione sonora NO: Lydtrykknivå SV: Ljudtrycksnivå DA: Lydtryksniveau FI: Äänenpainetaso ES: Nivel de presión sonora PT: Nível de pressão acústica EL: Επίπεδο πίεσης ήχου TR: Göre ses basıncı seviyesi SL: Raven zvočnega tlaka. HR: Razina zvučnog tlaka. SK: Hladina zvukového. CS: Hladina akustického tlaku PL: Poziom ciśnienia akustycznego HU: Hangnyomásszint RO: Nivel de presiune acustică BG: Ниво на звуково налягане RU: Уровень шума ET: Helisurve tase LV: Akustiskā spiediena līmenis LT: Garso slėgio lygis JA: 音圧レベル ZH: 声压级 KO: 음압 레벨 TH: ระดับความดันเสียง MS: Tahap tekanan bunyi</p>
16		dB(A) +/-2 дБ(A) +/-2	<p>EN: Sound power level L_{WA}. DE: Schalleistungspegel FR: Niveau de puissance acoustique NL: Geluidsvermogeniveau IT: Livello potenza sonora NO: Lydeffektnivå SV: Ljudeffektnivå DA: Lydeffektniveau FI: Äänen tehotaso ES: Potencia acústica PT: Nível de potência acústica EL: Επίπεδο ισχύος ήχου TR: Göre ses basıncı seviyesi SL: Raven moči zvoka. HR: Razina jakosti. SK: Hladina zvukového výkonu. CS: Hladina akustického výkonu PL: Poziom mocy akustycznej HU: Hangteljesítmény szint RO: Nivelul de putere acustică BG: Ниво на звукова мощност RU: Уровень звуковой мощности ET: Helivõimsuse tase LV: Akustiskās jaudas līmenis LT: Garso galios lygis JA: 音響パワーレベル ZH: 声功率级 KO: 소음 레벨 TH: ระดับกำลังเสียง MS: Tahap kuasa bunyi</p>
17		m/s ² 米/秒 ²	<p>EN: Vibration. DE: Vibrationen FR: Vibration NL: Vibratie IT: Vibrazioni NO: Vibrasjoner SV: Vibration DA: Vibration FI: Tärinäarvot ES: Vibración PT: Vibraçãoes EL: Δόνηση TR: Titreşimi SL: Vibracije. HR: Vibracije. SK: Vibrácie. CS: Vibrace PL: Drgania HU: Vibráció RO: Vibrații BG: Вибрации. RU: Вибрация ET: vibratsioon LV: vibrācija LT: Vibracijos JA: 振動。 ZH: 振动 KO: 진동 TH: แรงสั่นสะเทือน MS: Getaran.</p>

18		N	EN: Recoil forces, lance. DE: Rückstoßkraft, Sprühhrohr FR: Forces de recul, lance NL: Terugslagkracht, lans IT: Forze di rinculo, lancia NO: Rekylkraft, lanse SV: Rekylkraft, spolrör DA: Rekylkraft, dyserør FI: Rekyllivoimat, suutin ES: Fuerzas de retroceso, lanza PT: Forças de retrocesso, lança EL: Δυνάμεις οπισθοδρόμησης, διάταξη ψεκασμού χη. TR: Sarmal kuvvetler, boru SL: Povratne sile, šoba. HR: Trzajne sile, mlaznica. SK: Spätňý odraz, štandardná striekacia rúra. CS: Síly zpětného rázu, násadec PL: Siły odrzutu, lanca HU: Visszaható erő, szórósó RO: Forțe de recul, tija BG: Сили на откат, накрайник. RU: Сила отдачи (распылитель). ET: Tagasilöögijõud, otsik LV: Atsitiena spēks, smidzinātājs LT: Atatrankos jėga, antgalis JA: 反跳力、ランス。 ZH: 反冲力 (喷杆) KO: 반동력, 랜스 TH: แรงสะท้อนถอยหลัง, ปลายทอ MS: Kuasa sentakan, lans.
19		L 升	EN: Oil quantity. DE: Ölmenge. FR: Quantité d'huile. NL: Hoeveelheid olie. IT: Quantità olio. NO: Oljemengde. SV: Oljemängd. DA: Oliemængde. FI: Öljymäärä. ES: Cantidad de aceite. PT: Quantidade de óleo. EL: Ποσότητα λαδιού. TR: Yağ miktarı. SL: Količina olja. HR: Količina ulja. SK: Množstvo oleja. CS: Množství oleje. PL: Objętość oleju. HU: Olajmennyiség. RO: Cantitate de ulei. BG: Количество на маслото. RU: Количество масла. ET: Õli kogus. LV: Eļļas daudzums. LT: Tepalo kiekis. JA: オイル量。 ZH: 油量升 KO: 오일량 TH: ปริมาณน้ำมัน MS: Kuantiti minyak.
20			EN: Oil type. DE: Öltyp. FR: Type d'huile. NL: Olietype. IT: Tipo olio. NO: Oljetype. SV: Typ av olja. DA: Olietype. FI: Öljyn tyyppi. ES: Tipo de aceite. PT: Tipo de óleo. EL: Τύπος λαδιού. TR: Yağ tipi. SL: Vrsta olja. HR: Vrsta ulja. SK: Typ oleja. CS: Typ oleje. PL: Typ oleju. HU: Olaj típusa. RO: Tip de ulei. BG: Тип на маслото. RU: Тип масла. ET: Õli tüüp. LV: Eļļas tips. LT: Tepalo tipas. JA: オイルの種類。 ZH: 油型 KO: 오일 유형 TH: ประเภทน้ำมัน MS: Jenis minyak.
			EN: Specifications and details are subject to change without prior notice. DE: Technische Daten und Details des Geräts können sich ohne vorherige Ankündigung ändern. FR: Ces spécifications et détails sont susceptibles d'être modifiés sans préavis. NL: Specificaties en details kunnen zonder voorafgaande waarschuwing worden gewijzigd. IT: Specifiche e dettagli sono soggetti a modifiche senza preavviso. NO: Spesifikasjonene og detaljene er gjenstand for endringer uten forutgående varsel. SV: Specifikationer och information kan ändras utan föregående meddelande. DA: Ret til ændringer i konstruktion og specifikationer forbeholdes. FI: Rakenteeseen ja teknisiin tietoihin voidaan tehdä muutoksia ilmoittamatta niistä ennalta. ES: Las especificaciones y los datos están sujetos a cambios sin previo aviso. PT: As especificações e os detalhes estão sujeitos a alterações sem aviso prévio. EL: Τα τεχνικά χαρακτηριστικά και οι λεπτομέρειες υπόκεινται σε αλλαγές χωρίς προηγούμενη ειδοποίηση. TR: Özellikler ve ayrıntılar, önceden haber verilmeyen değiştirilebilir. SL: Tehnični podatki in podrobnosti se lahko spremenijo brez predhodnega obvestila. HR: Specifikacije i detalji mogu se mijenjati bez prethodne najave. SK: Špecifikácie a podrobnosti sa môžu meniť bez predchádzajúceho upozornenia. CS: Technické údaje a detaily mohou být změněny i bez předchozího upozornění. PL: Specyfikacje i parametry mogą zostać zmienione bez uprzedzenia. HU: A műszaki adatok és részletek előzetes értesítés nélkül megváltozhatnak. RO: Specificațiile și detaliile pot fi modificate fără înștiințare prealabilă. BG: Спецификациите и детайлите подлежат на промяна без предварително уведомление. RU: Технические характеристики и данные могут изменяться без предварительного извещения. ET: Tehnilisi kirjeldusi ja üksikasju võidakse muuta eelneva etteteatamiseta. LV: Specifikācijas un detaļas var tikt mainītas bez iepriekšēja paziņojuma. LT: Konstrukcija ir specifikacijos gali keistis be išankstinio įspėjimo. JA: 仕様および情報は事前通知無しに変更する場合があります。 ZH: 规格和详情如有变更, 恕不另行通知。 KO: 사양 및 내용은 예고없이 변경될 수 있습니다. TH: ข้อกำหนดเฉพาะและรายละเอียดสามารถเปลี่ยนแปลงได้โดยไม่ต้องแจ้งให้ทราบล่วงหน้า MS: Spesifikasi dan butiran adalah tertakluk kepada perubahan tanpa notis terlebih dahulu.



HEAD QUARTER

DENMARK

Nilfisk A/S
Kornmarksvej 1
DK-2605 Brøndby
Tel.: (+45) 4323 8100
www.nilfisk.com

SALES COMPANIES

ARGENTINA

Nilfisk Argentina
Herrera 1855 Piso 4° B Ofic 405
Ciudad de Buenos Aires
Tel.: (+54) 11 6091 1576
www.nilfisk.com.ar

AUSTRALIA

Nilfisk Pty Ltd
Unit 1/13 Bessemer Street
Blacktown NSW 2148
Tel.: (+61) 2 98348100
www.nilfisk.com.au

AUSTRIA

Nilfisk GmbH
Metzgerstrasse 68
5101 Bergheim bei Salzburg
Tel.: (+43) 662 456 400 90
www.nilfisk.at

BELGIUM

Nilfisk n.v.-s.a.
Riverside Business Park
Boulevard Internationalelaan 55
Bâtiment C3/C4 Gebouw
Bruxelles 1070
Tel.: (+32) 24 67 60 50
www.nilfisk.be

BRAZIL

Nilfisk do Brasil
Av. Eng. Luis Carlos Berrini, 550
40 Andar, Sala 03
SP - 04571-000 Sao Paulo
Tel.: (+11) 3959-0300 / 3945-4744
www.nilfisk.com.br

CANADA

Nilfisk Canada Company
240 Superior Boulevard
Mississauga, Ontario L5T 2L2
Tel.: (+1) 800-668-8400
www.nilfisk.ca

CHILE

Nilfisk S.A. (Comercial KCS Ltda)
Salar de Lamara 822
8320000 Santiago
Tel.: (+56) 2684 5000
www.nilfisk.cl

CHINA

Nilfisk
4189 Yindu Road
Xinzhuang Industrial Park
201108 Shanghai
Tel.: (+86) 21 3323 2000
www.nilfisk.cn

CZECH REPUBLIC

Nilfisk s.r.o.
VGP Park Horní Počernice
Do Čertous 1/2658
193 00 Praha 9
Tel.: (+420) 244 090 912
www.nilfisk.cz

DENMARK

Nilfisk Danmark A/S
Industrivej 1
Hadsund, DK-9560
Tel.: 72 18 21 20
www.nilfisk.dk

FINLAND

Nilfisk Oy Ab
Koskelontie 23 E
02920 Espoo
Tel.: (+358) 207 890 600
www.nilfisk.fi

FRANCE

Nilfisk SAS
26 Avenue de la Baltique
Villebon sur Yvette
91978 Courtabouef Cedex
Tel.: (+33) 169 59 87 00
www.nilfisk.fr

GERMANY

Nilfisk GmbH
Guido-Oberdorfer-Straße 2-10
89287 Bellenberg
Tel.: (+49) (0)7306/72-444
www.nilfisk.de

GREECE

Nilfisk A.E.
Αναπαύσεως 29
Κορωπί T.K. 194 00
Tel.: (30) 210 9119 600
www.nilfisk.gr

HOLLAND

Nilfisk B.V.
Versterkerstraat 5
1322 AN Almere
Tel.: (+31) 036 5460760
www.nilfisk.nl

HONG KONG

Nilfisk Ltd.
2001 HK Worsted Mills
Industrial Building
31-39, Wo Tong Tsui St.
Kwai Chung, N.T.
Tel.: (+852) 2427 5951
www.nilfisk.com

HUNGARY

Nilfisk Kft.
II. Rákóczi Ferenc út 10
2310 Szigetszentmiklós-Lakihegy
Tel.: (+36) 24 475 550
www.nilfisk.hu

INDIA

Nilfisk India Limited
Pramukh Plaza, 'B' Wing, 4th floor, Unit
No. 403
Cardinal Gracious Road, Chakala
Andheri (East) Mumbai 400 099
Tel.: (+91) 22 6118 8188
www.nilfisk.in

IRELAND

Nilfisk
1 Stokes Place
St. Stephen's Green
Dublin 2
Tel.: (+35) 3 12 94 38 38
www.nilfisk.ie

ITALY

Nilfisk SpA
Strada Comunale della Braglia, 18
26862 Guardamiglio (LO)
Tel.: (+39) (0) 377 414021
www.nilfisk.it

JAPAN

Nilfisk Inc.
1-6-6 Kita-shinyokohama, Kouhoku-ku
Yokohama, 223-0059
Tel.: (+81) 45548 2571
www.nilfisk.com

MALAYSIA

Nilfisk Sdn Bhd
Sd 33, Jalan KIP 10
Taman Perindustrian KIP
Sri Damansara
52200 Kuala Lumpur
Tel.: (60) 3603 627 43 120
www.nilfisk.com

MEXICO

Nilfisk de Mexico, S. de R.L. de C.V.
Pirineos #515 Int.
60-70 Microparque
Industrial WSantiago
76120 Queretaro
Tel.: (+52) (442) 427 77 00
www.nilfisk.com

NEW ZEALAND

Nilfisk Limited
Suite F, Building E
42 Tawa Drive
0632 Albany Auckland
Tel.: (+64) 9 414 1996
Website: www.nilfisk.com

NORWAY

Nilfisk AS
Bjørnerudveien 24
1266 Oslo
Tel.: (+47) 22 75 17 80
www.nilfisk.no

PERU

Nilfisk S.A.C.
Calle Boulevard 162, Of. 703, Lima 33-
Perú
Lima
Tel.: (511) 435-6840
www.nilfisk.com

POLAND

Nilfisk Sp. Z.O.O.
Millenium Logistic Park
ul. 3 Maja 8, Bud. B4
05-800 Pruszków
Tel.: (+48) 22 738 3750
www.nilfisk.pl

PORTUGAL

Nilfisk Lda.
Sintra Business Park
Zona Industrial Da Abrunheira
Edificio 1, 1° A
P2710-089 Sintra
Tel.: (+351) 21 911 2670
www.nilfisk.pt

RUSSIA

Nilfisk LLC
Vyatskaya str. 27, bld. 7/1st
127015 Moscow
Tel.: (+7) 495 783 9602
www.nilfisk.ru

SINGAPORE

Den-Sin
22 Tuas Avenue 2
639453 Singapore
Tel.: (+65) 6268 1006
www.densin.com

SLOVAKIA

Nilfisk s.r.o.
Bancíkovej 1/A
SK-821 03 Bratislava
Tel.: (+421) 910 222 928
www.nilfisk.sk

SOUTH AFRICA

Nilfisk (Pty) Ltd
Kimbult Office Park
9 Zeiss Road
Laser Park
Honeydew
Johannesburg
Tel: +27118014600
www.nilfisk.co.za

SOUTH KOREA

Nilfisk Korea
#204 2F Seoulsup Kolon Digital Tower
25 Seongsuil-ro 4-gil, Seongdong-gu
Seoul.
Tel.: (+ 82) 2 3474 4141
www.nilfisk.co.kr

SPAIN

Nilfisk S.A.
Torre d'Ara,
Passeig del Rengle, 5 Plta. 10ª
08302 Mataró
Tel.: (34) 93 741 2400
www.nilfisk.es

SWEDEN

Nilfisk AB
Taljegårdsgatan 4
431 53 Mölndal
Tel.: (+46) 31 706 73 00
www.nilfisk.se

SWITZERLAND

Nilfisk AG
Ringstrasse 19
Kircheberg/Industri Stelz
9500 Wil
Tel.: (+41) 71 92 38 444
www.nilfisk.ch

TAIWAN

Nilfisk Ltd
Taiwan Branch (H.K)
No. 5, Wan Fang Road
Taipei
Tel.: (+88) 6227 00 22 68
www.nilfisk.tw

THAILAND

Nilfisk Co. Ltd.
89 Soi Chokechai-Ruammitr
Viphavadee-Rangsit Road
Ladyao, Jatuchak, Bangkok 10900
Tel.: (+66) 2275 5630
www.nilfisk.co.th

TURKEY

Nilfisk A.S.
Serifali Mh. Bayraktar Bulv. Sehit Sk. No:7
Ümraniye, 34775 Istanbul
Tel.: +90 216 466 94 94
www.nilfisk.com.tr

UNITED ARAB EMIRATES

Nilfisk Middle East Branch
SAIF-Zone
P.O. Box 122298
Sharjah
Tel.: (+971) (0) 655-78813
www.nilfisk.com

UNITED KINGDOM

Nilfisk Ltd.
Nilfisk House, Bowerbank Way
Gilwilly Industrial Estate, Penrith
Cumbria CA11 9BQ
Tel.: (+44) (0) 1768 868995
www.nilfisk.co.uk

UNITED STATES

Nilfisk, Inc.
9435 Winnetka Ave N,
Brooklyn Park
MN- 55445
www.nilfisk.com

VIETNAM

Nilfisk Vietnam
No. 51 Doc Ngu Str.
P. Vinh Phuc, Q.Ba Dinh
Hanoi
Tel.: (+84) 761 5642
www.nilfisk.com